

ARK-20xx

Hardware Manual

v10.08.02



INDEX

1.- INTRODUCTION.	
ARK Description.....	5
Description of the ARK's front panel	6
Description of the ARK's back panel.....	7

2.- SETUP AND CONNECTION	
Connectors and connections.....	8
ARK dimensions	8

3.- FUNCTIONAL DESCRIPTION.	
Block diagrams	9

4.- OPERATING INSTRUCTIONS.	
Operating procedures	11
Display and encoder	12
Program menus	13
- Open Preset	13
- Input Gain	14
- Input Polarity	14
- Input Delay	15
- Output Route	15
- Output Gain	16
- Output Polarity	16
- Output Delay	17
- Firmware	17

5.- SPECIFICATIONS.	18
----------------------------------	----

6.- TROUBLESHOOTING.	19
-----------------------------------	----

7.- GUARANTEE.	20
-----------------------------	----



WELCOME

Just contact the new generation of digital processors **ARK**, designed and manufactured by VMB Española S.A

Before working with the processor we recommend that you read this manual, in its pages you will find instructions for use, programming examples and practical advice that will be of great help. Also consider reading the Software manual, available separately and easily downloadable from the vmb web www.vmb.es.

For the maximum optimization of any sound system a first class digital processor with different processing options is required. Thus **ARK** processors become a working tool of great value, providing the user with the best solutions in the market with the highest level of accuracy and a host of features for the professional.

We hope that as a user you will be completely satisfied. We are sure that the **ARK** processor will meet your expectations and make it easier for you to get the most out of your system.

IMPORTANT SAFETY INSTRUCTIONS-



The **CE** mark of the **MultiDAC** processor shows that it is verified and tested to accomplish the European Norms and International Norms about Electromagnetic Compatibility and Electrical Safety.

Radiated Emissions : EN55013-1 (1996)
RF Immunity: EN55103-2 (1996)
Electical Safety: EN60065 (1993)
IEC65 (1985) and emendation 1, 2 and 3

This product also meets the specifications of the following safety directives:

Low Voltage Directive 73/23/EEC
EMC Directive 89/336/EEC



Product Developed and Manufactured in the European Union.

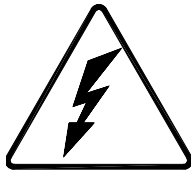

**PRECAUCION
RIESGO DE SHOCK ELECTRICO
NO ABRIR**

**CAUTION
RISK OF ELECTRIC SHOCK
DO NOT OPEN**



The symbols shown above are internationally accepted symbols that warn of potential hazards with electrical products. The lightning flash with arrowpoint in an equilateral triangle means that there are dangerous voltages present within the unit. The exclamation point in an equilateral triangle indicates that is necessary for the user to refer to the owner's manual.

Warning :

- Do not expose the processor to humidity and dust.**
- Do not take off the top cover.**
- Do not handle internal elements to avoid electrical shock.**
- Use only power cords in good condition.**

Unpacking the ARK .-

Before unpacking your new processor, verify that the box does not show any damage or deformation. If this happens, please claim the damage to your forwarder. Once unpacked and verified its correct operation, keep the original box in case you need to ship it back to your provider.

1.-INTRODUCTION

ARK-20 series offers the user a perfect tool for processing, with three processor models available (ARK-2024, ARK-2026, ARK-2048) with two or four inputs and eight outputs.

ARK-20 series processors offer a RMS compressor/limiter used to adjust the sound level of the transducer, keeping the original dynamics while respecting the original transition, getting a better acoustic result. This Dynamic minimizes distortion levels and provides protection for all acoustic and electronic components of the system.

With fixed latency of 0.6 ms ARK processors offer one of the lower latencies on the market. All ARK models offer 120 dB dynamic range and AD-DA converter Cirrus Logic high-performance 24-bit and 96 KHz. The internal DSP processor works with double precision floating point, reaching a 56-bit internal resolution, one of the highest resolutions available today on the market. This allows the use of high-precision filters with very low distortion and providing a quality and unsurpassed sound clarity.

In the security section, different levels of access restrictions are included. That can be managed by a global password and a preset password, with the choice to select which processing functions can be modified or not. The front panel can also be blocked, denying any access.

For the available ARK control software, we recommend reading the software manual. The control software for ARK processors is designed to provide the user with fast and intuitive access to each process area, facilitating the programming of the processor from a computer. The software manual is a document available in the downloads section of the website www.vmb.es

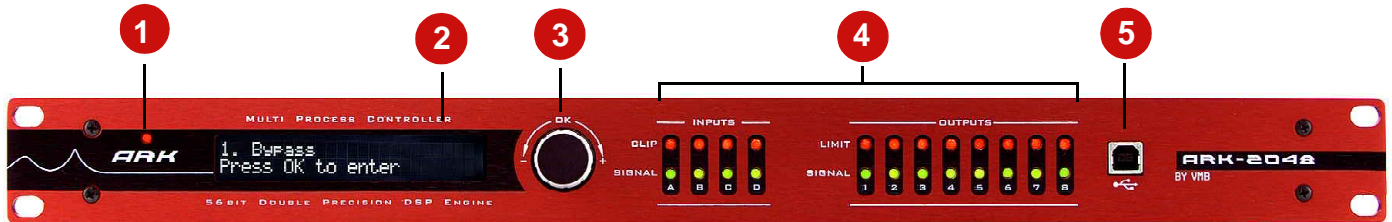
ARK20's front panel description-**1.- POWER SUPPLY INDICATION.**

Indicates that the processor is switched on.

2.- LCD DISPLAY.

24 characters LCD Display. Shows the menus, function information, and various user editable parameters.

3.- ENCODER.

Encoder with pushbutton from which we can modify move into the menu

4.- SIGNAL, LIMITATION AND CLIP LEDS.**5.- USB.**

USB connection from the frontal to set parameters or update the firmware via ARK software.

ARK20 Back panel description.-

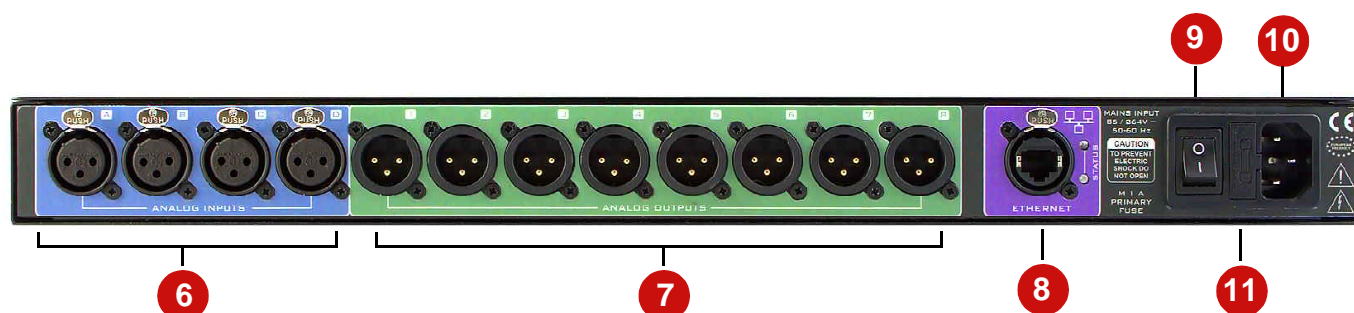

6.- AUDIO INPUTS.

Analog: Balanced signal via female XLR connectors.

7.- AUDIO OUTPUTS.

Analog: Balanced signal via male XLR connectors.

8.- ETHERNET CONNECTOR (OPTIONAL).

Ethercon RJ45 professional connector for a secure connection.

9.- POWER ON SWITCH.

10.- IEC MAIN POWER CONNECTOR .

The power cord is supplied together with the processor. The **ARK** includes a precise switching power supply. It withstands power supply from 85 to 264 volts and is continuously self-regulating providing a perfect functioning even with poorly regulated voltages.

11.- FUSE HOLDER.

1A fuse. (Always replace with equivalent fuses)

2.- SET UP AND CONNECTION

Connectors and connections.

XLR SOCKET CONECTORES

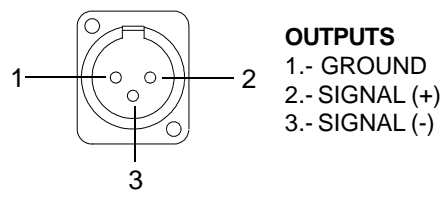
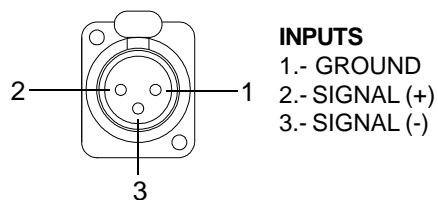

OVERHEAD XLR CONNECTORS

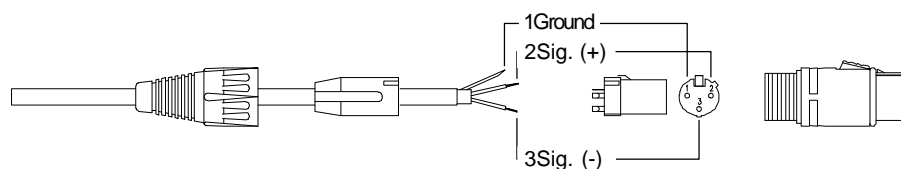
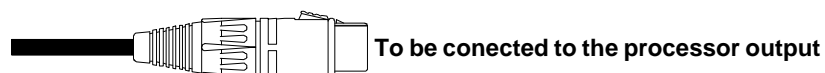
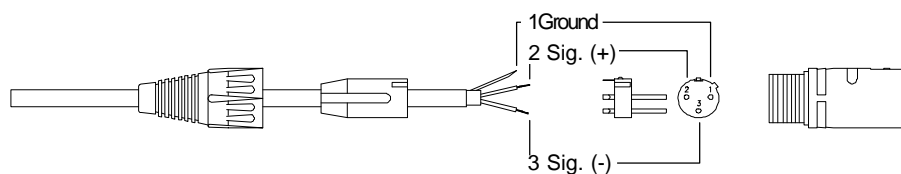
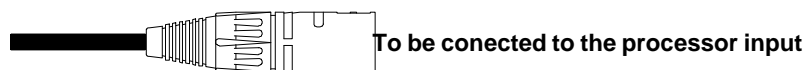

ARK dimensions (in mm).



3.- FUNCTIONAL DESCRIPTION

ARK-20 Process Diagram.

Four floating point DSPs (Digital Signal Processors) with 56 bits of internal resolution are included in the **ARK** processor. All this calculating power is used in the signal processing algorithms which control all the process: input delays, global equalisation, crossover filters, individual equalisation for each way, output delays, protections and dynamic control and independent noise gate per output. All of these algorithms have been developed to provide the best precision and the lowest round-off noise in the calculations. This way, the best sound fidelity and transparency free of noise is achieved. The wide internal range (56 bit) allows the use of high-precision filters with very low distortion. Cirrus Logic converters 24-bit and 120 dB dynamic range assures a clean sound without distortion and background noise makes the ARK-20 one of the processors in the market with the best technical characteristics.

Once the analog input signal is converted into a digital one, the processing inside the **ARK** DSPs is as follows:

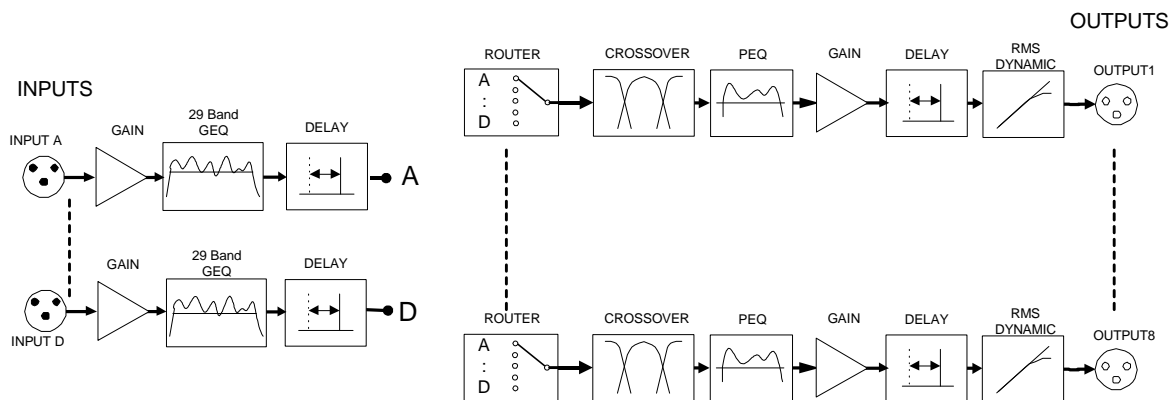

GAIN: Gain control. Gain adjusting in inputs to adapt/fit the signal level sent from the mixing console and in the outputs to adjust the level supplied to each amplifier and to equalize the sensitivity in each way.

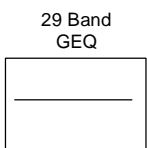

GEQ: ARK-20 offers for each input a 29-band graphic equalizer with two choices of Q, the classical and a special algorithm, which adapts the Q in terms of how are the other filters, to get a smoother response and more optimal acoustics.

DELAY

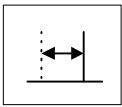

DELAY: Configurable delay. In the inputs A-B up to 54 msec, for covering a distance up to 18 m It is mainly useful when working with important PA equipment covering a large distance with reinforcement blocs. It allows 20 msec at outputs, which correspond to 7 meters approximately. Thanks to that function, it is possible to rectify the cabinet's position (alignment) in a multi-way equipment and avoid cancelling problems due to phase cancellation effects.

PEQ

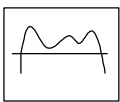

PEQ: Output equalisation. There are 9 filters completely configurable per output. These filters can be parametric, 6dB/oct. and 12dB/oct. low frequencies Shelving (with or without Q), 6dB/oct. and 12dB/oct. high frequency Shelving (with or without Q), 12 dB/oct. highpass and lowpass, bandpass, reject band and first and second order Allpass filters. Its aim is to provide a final equalisation on each way of the equipment.

CROSSOVER

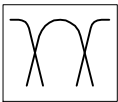

CROSSOVER: Bands separating filters. Different filters are available: Linkwitz-Riley, Butterworth and Bessel up to 48 dB/oct. It is also possible to put them in By-pass without affecting the corresponding way to have full bandwidth output.

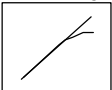
RMS
DYNAMIC

DYNAMIC: Dynamic section. The **ARK-20** offers a sophisticated RMS compressor-limiter on each output. Limiters and compressors are C.R.I. type (Continuous Increment Ratio) for low distortion.

Using a RMS detector for a high-quality compression. The system will reach its maximum power gradually and the sound is perfectly crisp and clear at all times, avoiding the usual problems of normal limiters. Also available is a noise gate that will respond with the same timing as the RMS dynamics and you can select different thresholds of noise to remove.

On the ARK front can see when a via is limiting because **LIMIT LED** lights.

4.- OPERATING INSTRUCTIONS.

How to proceed.-

a. - Before switching on the processor:

ARK includes a precise switching power supply. That means that it can adapt itself to any input supply voltage from 84 and 264 volts and frequencies from 50 to 400 Hz. This is the reason why the processor is guaranteed to work perfectly under any voltage and the final sound quality is completely independent of the supply voltage or the kind of generator used. Nevertheless it is recommended to check the supply voltage before working to avoid any possible problem when connecting at 380 volts. A fuse holder is included in the **ARK** processor with a spare fuse (1 A) situated in the IEC connector input of the power supply connector.

It is recommended to turn off the volume of all the power amplifiers down to 0 before switching on the processor. We will then be able to check whether any of the 4 processor outputs are connected to their corresponding power cabinets, avoiding any irretrievable damage in the loudspeakers (specially in expensive high frequencies drivers).

In any installation, it is suitable to place audio and lighting systems in independent power lines to protect both parts separately and to avoid interferences between the different equipments.

b. - Once the processor is ON:

When switching on the **ARK** processor, audio outputs remain short-circuited to ground for a few seconds in order to avoid the dangerous start up transient time necessary for the processor to receive a stable voltage and to check internal functions such as: good running of the converters, working memory checking, DSP processors start-up and current configuration loading. Subsequently, if everything is correct, all the outputs will commutate at the same time introducing audio in each output with a soft-start (The audio be increased until reaching the value set in the preset).

Display, buttons and encoders.-

ARK processor comes, for programming all functions, with a 24 characters and two lines LCD display, as well as an encoder to move into the menu. **It is recommended to use the ARK software for better viewing of EQ curves and ease of programming.**

ENCODER DESCRIPTION:

The encoder allow modification of menu items and move us by menus and submenus.



RIGHT: Increase the number of menu.

LEFT: Decrease the number of menu.

PUSH OK: Provides access to menus and submenus and confirm their actions

Program Menus.-

ARK Processor has an LCD Display in which there are various configuration menus to store and modify the operation of processor options and to protect stored data and access to them.

These menus are:

- Open Preset
- Input Gain
- Input Polarity
- Input Delay
- Output Route
- Output Polarity
- Output Delay
- Firmware

When switching the processor, the start menus appears:

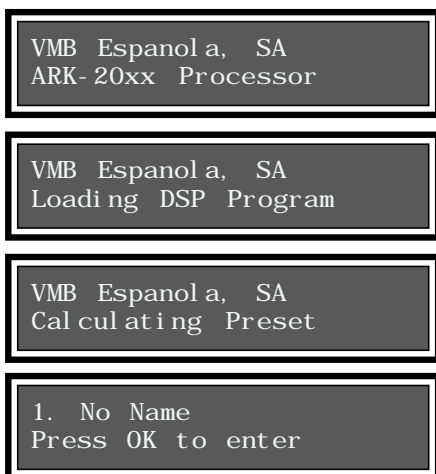

Load the DSP program.

Calculate and send preset data to the present DSP.

Initially in the first line shows the memory number and name of the current program.

Pressing the function **OK** allows you to enter the detailed configuration of the functions of the processor.

Open Preset

The **Open Preset** menu is the first to find when you press **OK** after the welcome menu.

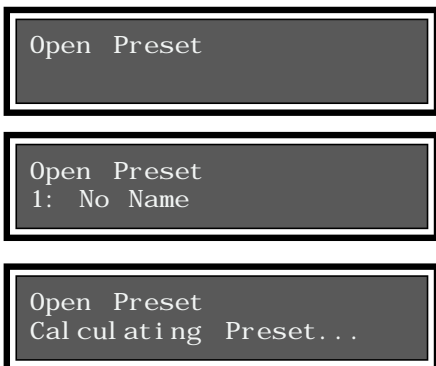

If we press **OK** we will select the memory we want to load using the encoder.

Memory number will be displayed and the name of the preset selected.

If we accept, the memory will be loaded and the following screen appears.

Input Gain

If we increase with the encoder, we move to submenu **Input Gain**, from which we can change the gain of the input A, B, C and D.



Pressing **OK** we access the next window, in which we can modify with **encoder** the **gain** of each input (from -40 dBu to +6dBu).



At the top-left of the display shows the Input in which we are, initially input A. Pressing OK will confirm and go to the next input. Any movement of the encoders will be sent in real-time to DSP.



Input Polarity

If we increase again with the encoder, we move to submenu **Input Polarity**, from which we can change the polarity of the input A, B, C and D.



Pressing **OK** we access the next window, in which we can modify with **encoder** the **polarity** of each input (Positive or negative).



At the top-left of the display shows the Input in which we are, initially input A. Pressing OK will confirm and go to the next input. Any movement of the encoders will be sent in real-time to DSP.



Input Delay

Increasing the menu, we move to submenu **Input Delay**, from which we can change the delays for inputs A, B, C, D.



Delay in milliseconds

Delay in meters

Pressing **OK** will access the next screen, in which we can increase or decrease with **encoder** the **delay** of the current input. This will increase from 0 to 54ms (18.77 meters at 25°C) for inputs A-B.

With **push** we change to the next input.

Output Route

Next submenu is **Output ROUTE**, from here we can select from where we take the input signal on every output.

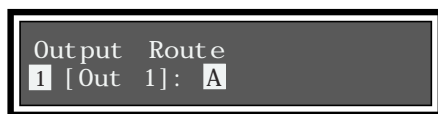

Again we enter the submenu by pressing **OK**, in which we choose the desired input signal for the selected output, in this case OUT 1 takes the signal from input A. We can choose inputs A, B, C, D as well as mono A+B, C+D (for inputs A+B and C+D the input gain decrease to -6dB automatically, to compensate the sum of both channels). We will change the output selection pressing **OK**.

The processor will show in brackets the name we have assigned for such outputs with ARK software.

Output Gain

If we increase the menu will pass to the **Output Gain** submenu, from which we can modify the gain of the selected output 1 to 8.



Pressing **OK** will access the next screen, in which we can modify with **encoder** the **gain** of the selected output (from -40 dBu to +6dBu). The top-left of the display shows the output in which we are. The 1, in this case. Any movement of the encoders will be sent in real-time to the DSP. To change the output just push **OK**.

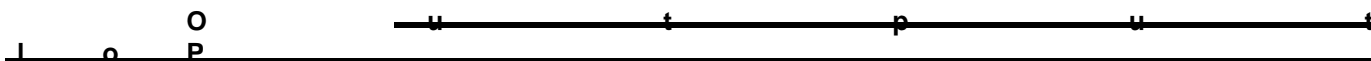

Increasing the menu will go to **Output Polarity** submenu, from which we can modify the polarity of the selected output 1 to 8.



Pressing **OK** will access the next screen, in which we can modify with **encoder** the **polarity** of the selected output (positive or negative). The top-left of the display shows the output in which we are. 1, in this case. Any movement of the encoders will be sent in real-time to the DSP. To change the output just push **OK**.

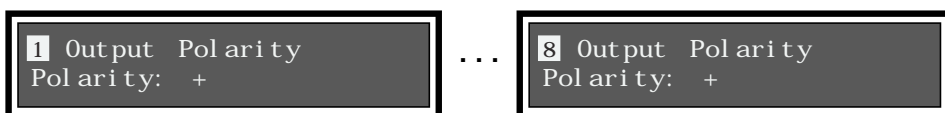

Output Delay

Next submenu to come is the **Output Delay**, from which we can modify delays in outputs 1, 2, 3, 4, 5, 6, 7 and 8.



Delay in milliseconds

Delay in meters

Pressing **OK** we will access a new screen, in which we can modify **Delay** for the selected output with the **encoder**. This range will be from 0 to 20.83ms (7.22 meters at 25°C) for each output.

With **encoder Push** we confirm and go to the next Output.

Firmware

And the last submenu is the **Firmware**, from which we can get information about version of the current firmware and release date.

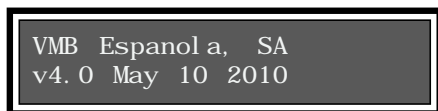

Pressing **OK** show the information.

5.- TECHNICAL SPECIFICATIONS.

Input 2 / 4
 Impedance: 20 K Ohm Balanced (10 K Ohm unbalanced)
 Connector: Balanced XLR (pin 2 +)
 AD converter: 24 bit-192KHz, 512x Oversampling
 Dynamic Range: 120 dB
 Max. level: +19 dBu (balanced).

Outputs 4 / 6 / 8 (ARK-7024 / 7044 / 7026 / 7048)
 Impedance: 50 Ohm Balanced (25 Ohm unbalanced)
 Connector: Balanced XLR (pin 2 +)
 DA converter: 24 bit-192KHz, 512x Oversampling
 Dynamic Range: 120 dB
 Max. level: +18 dBu (balanced)

Audio
 Frequency Range 10 Hz – 24 KHz
 THD (%) <0,0018%
 DSP Process Internal resolution with 56 bit double precision in floating point
 Converters 24 bit resolution
 Propagation Delay: 0.6 milliseconds

Equalisation
 Input GEQ 29 GEQ Bands per input
 PEQ output 9 per way
 PEQ Type filters Parametric, Shelving High, Shelving Low, Low-Pass, High-Pass, Low-Pass Q variable, High-Pass Q variable, BandPass, Reject Band, AllPass order 1, AllPass order 2.

Crossover
 Linkwitz Riley with 12, 24, 48 dB/oct.
 Butterworth and Bessel with 6, 12, 18, 24, 30, 36, 42 and 48 dB/oct.

Delay
 Input 54.15 milisec
 Output 20.8 milisec for Speaker's alignment

RMS Limiter-Compressor
 1 per output.
 Threshold: +18dBu to -50dBu
 Compression Ratio: 1:1 to 1:10 (1:infinite with limiter)
 Power indication Shows the maximum power applied to the speaker for the selected threshold.

Noise Gate
 1 per Output
 Noise Threshold: -79dBu to -37dBu.

Level Control
 Gain +6dBu to -40 dBu per input / output

Signal Generator
 Level 0dBu to -40dBu
 Type: sin tone from 10Hz to 22KHz, Pink noise, White noise.

Security Options
 Password global
 Level 0: All controls unlocked.
 Level 1: Only permits to change presets. All frontal controls locked.
 Level 2: Restricted Zones: For each Preset it is possible to disable the access to any processor function (EQ, crossover, Limiter, etc) writing a preset password.

Other functions:
 Process Integration with RAINBOW – The acoustical prediction software
 Speaker data import from main audio measurement systems.
 Export & Import EQ files
 Etc.

Front Panel
 Display: LCD with 24 x 2 characters.
 Encoders: 1 with push button.

Level Meter: Input signal, input clip, output signal, output Limiter on

Communication USB
 Ethernet (optional).

General
 Power supply 85-240 V ~ 40-400 Hz. IEC connector. (Switching power supply, wide range)
 Consumption 30 W

Operating temperature: -5° to 60° C (23° to 140° F)
 Storage temperature: -60° to 75° C (-76° to 167° F)
 Humidity: Max. 90% non-condensing

Dimensions 482 x 45 x 226 mm
Weight 3 Kg
Warranty 3 years

6.- TROUBLESHOOTING

In this section we try to give solutions to possible problems :

1 – The processor does not start up:

Check the power supply cord. If it is correctly connected and the red led on the front panel does not light on, check the fuse situated in the input of the power cord.

2 – The processor starts up but there is no sound:

Check that the processor is being provided with a signal in the correct input, A, B, C or D. If the signal does reach the processor, the green signal LED will light, otherwise check all the connections from the mixing console to the processor.

3 – The resulting sound is “strange”:

Check that the 4 outputs and their corresponding cabinets are correctly linked. Always be careful in increasing little by little the cabinets volume channel by channel in order to check the correct connection and not to damage the transducers.

4 – One of the cabinets (with the same signal) sounds less than the others:

Check that the joining cable from the processor to the cabinet is well balanced otherwise the output signal will fall 6 dB.

5 – Audio sounds wrong and distorted.

Verify that we are not saturating the input (beyond the 19 dBu input). In this case the LEDs light up red clip. Sufficient to reduce the input signal to the processor, until no clip LEDs light up. If this does not work, verify that the signal is not distorted out from the previous gear, for example the mixer, which could be the gain of that channel very high and saturating the mixer input.

6 – Buttons or encoder do not work.

Verify if there is any keyboard lock activated from the software.

7 – I can not connect by Ethernet.

Check that the USB cable is not connected, it has priority and internally disables the Ethernet connection. If this is not the case read Annex Ethernet in the software manual.

7.- GUARANTEE

VMB's products are guaranteed against every kind of manufacturing defect for 1 year after the date of sale.

When products are under guarantee, the repairing and the free supplying of the defective parts in order to correct any kind of defect are guaranteed by VMB.

In the case that the product could not be returned to the factory for checking and repairing, VMB would supply all the necessary parts after identification of the original owner of the product or the authorized seller.

VMB is not responsible for any damage or defect caused during the transport or caused by an undue or improper handling a non-authorized person during the life of this guarantee.

VMB thanks you for relying on its product and hopes you will be completely satisfied with it.

All rights reserved. No reproduction of any part of the document may take place without the written permission of **VMB Española, S.A.**

VMB Española, S.A. is not responsible before the purchaser of this product nor with third parties for any damage, loss or cost that an accident, an inappropriate use or abuse of this product could generate to the purchaser or third parties. **VMB Española, S.A.** is not responsible either for modifications, reparings or alterations of the product or the non-strict observation of the functioning and maintenance instructions of **VMB Española, S.A.**

ARK are brands of **VMB Española, S.A.**

Microsoft and Windows are brands registered by Microsoft Corporation.

Other names of products have been used in this document just for identification purposes and they are commercial brands of their respective owners.

VMB is continuously working in order to improve the quality of its products.

The specifications herein described can undergo some change without previous announcement. The specifications of any new product from VMB will be as equal as the ones of the former product or will even be much better.

Copyright© 2010 VMB Española, S.A.
Todos los derechos reservados.

Editado en España por VMB Española, S.A.



VMBESPAÑOLA S.A.

Pol. Ind. Picassent - Calle 2, final - 46220 Picassent (VALENCIA) Spain
Tel.: +34 902 34 10 34 - Fax: +34 961 22 11 77 - Web: www.vmb.es - E-mail: contact@vmb.es



